

**Reliable external
oil-hydraulic operator**

HINDI 880



Thanks to its advanced technology and compact design, the HINDI 880 oil-hydraulic piston is long lasting, reliable and safe during use, intelligent, as it ensures full torque control, and weather resistant. This versatile product is available in a wide range of different versions, guaranteeing an automation able to provide the ideal solution for all installer and user requirements.

- **Manual release with customized key**
- **Easy and safe gate driving force regulation**
- **Adaptable to fit any type of installation**
- **Available with braking system during opening and closing**
- **Protective casing in anodized aluminium**
- **Connection to the gate with adjustable spherical head**

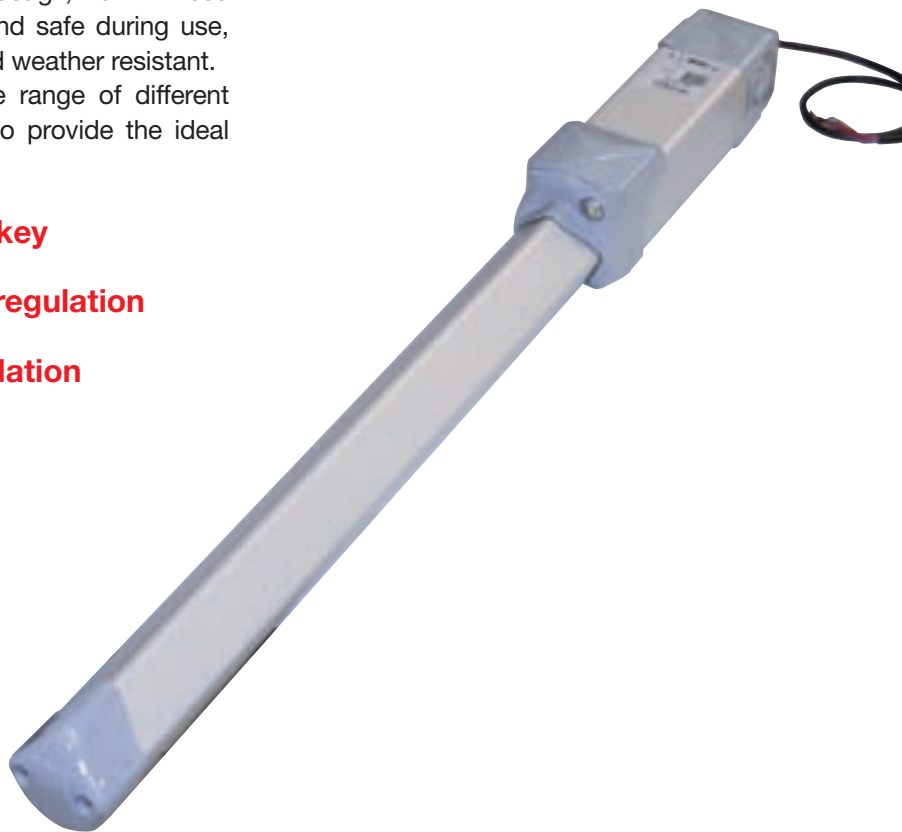

Back plate with swivel fork



Detail of adjustable spherical head



Valve casing with sliding lid:
manual release and pressure
adjustment valves



HINDI 880 TECHNICAL SPECIFICATIONS

Electric Motor

Power output	180 W (0.25 HP)
Power supply voltage / Frequency	230 V - 50 Hz
Absorbed power	300 W
Absorbed current	1.3 A
Motor rotation speed	1'350 r.p.m.
Capacitor	12.5 µF
Intermittent service	S 3 - 25%
Insulation class	F

Oil-hydraulic piston and hydraulic pump

Shaft excursion speed	24 s
P5 - Hydraulic pump capacity	1.4 l/min.
Piston stroke	280 mm
Piston diameter	45 mm
Shaft diameter	20 mm
Thrust power	3'000 N
Average working pressure	1 MPa (10 bar)
Maximum pump pressure	3 MPa (30 bar)
Hydraulic oil type	Oil Fadini
Working temperature	-25°C +80°C
Weight complete with accessories	11 Kg
Maximum gate weight	150 / 180 Kg
Dimensions (length x width x height)	1'085 x 92 x 110 mm
Protection standard	IP 553

Performance

Service cycle	25 s Opening - 30 s Dwell - 25 s Closing - 30 s Dwell
Complete cycle time	110 s
Complete Opening - Dwell - Closing - Dwell cycles	33/hour
Annual cycles (with 8 hours of use per day)	96'000

HINDI 880 DIMENSIONS

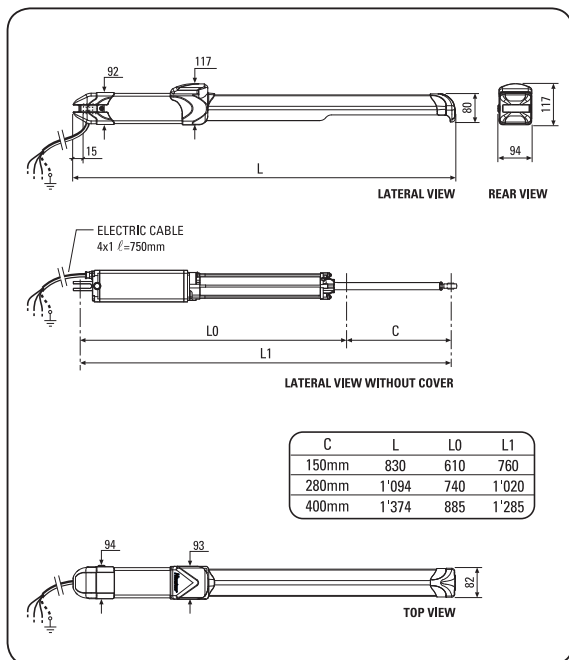

HINDI 880 VERSIONS

Piston stroke	Gate Leaf Length	Time
150 mm	max 1.50 m	12 s
280 mm	max 3.0 m	25 s
400 mm	max 5.0 m	32 s

We recommend using the electric lock for lengths of over 2 metres

Models

- Non locking - Locking on closed gate - Two-way locking
- With braking system during opening and closing

Components for installing HINDI 880

