

# RAPISCAN 622XR

Feature-rich X-ray baggage inspection system for screening large carry-on baggage and parcels at the checkpoint.

Large Baggage and Parcel Screening

Adjustable Control Panel

Network Enabled

Performance and Value



The Rapiscan 622XR offers high performance threat detection and lower total cost of ownership. With a tunnel opening of 750mm x 550mm, the Rapiscan 622XR can accommodate a range of parcel and baggage sizes for checkpoints. The 622XR's innovative design allows for bidirectional operation, while its dual-energy detection provides automatic material discrimination so that screeners can identify the material composition of the scanned object. In addition, it offers options like an adjustable control panel stand and swing-open, easy-access panels.

The Rapiscan 622XR, complies with U.S. Code of Federal Regulations (CFRs) on performance standards for ionizing radiation-emitting products, electronics products, radio frequency devices, qualification of screening personnel, occupational noise exposure and occupational safety and health standards.

Tunnel Opening (width x height):  
750 x 550 mm (29.5 x 21.7 in)

## Standard Features

- Multi Energy Imaging (4 Color)
- View Previous/Next Bag
- Manual Image Archive
- Configurable Image Processing Keys
- Baggage Counter
- Date / Time Display
- Search Indicator
- UPS (Uninterrupted Power Supply)
- Flat Panel Monitor

## Standard Image Processing Functions

- Crystal Clear™
- Black and White
- Organic / Inorganic Stripping
- Inverse Video
- High Penetration
- Pseudo Color
- Low Penetration
- Variable Edge Enhancement
- Variable Color Stripping
- Variable Gamma
- Variable Density
- Dynamic Continuous Zoom & Panning
- Fixed Zoom (64x)

### Automatic Detection of Explosives

Target™ automatically detects a wide range of explosives in real time during the scanning process by visibly highlighting a potential threat on the X-ray image.

### Automatic Detection of Narcotics

NARCSan™ automatically detects a wide range of narcotics in real time during the scanning process by visibly highlighting a potential threat on the X-ray image.

### Meeting Today's Most Stringent Global Requirements

Rapiscan 622XR meets the most rigorous detection and image quality requirements as set by the U.S. Transportation Security Administration (TSA) and French civil aviation authority (STAC).

### Greatest Number of Operator-Assist Tools Enables Highest Throughput

With over 13 image processing tools and multiple automatic detection functions, the feature rich software helps the operator easily and accurately detect contraband for the highest throughput and least operator fatigue.

### Regulatory Compliance

Rapiscan 622XR image quality performance is in compliance with regulation (EC) No. 300/2008. In addition, Rapiscan 618XR Threat Image Projection (TIP) is in compliance with regulation (EU) No. 185/2010.



[www.rapiscansystems.com](http://www.rapiscansystems.com)

**Rapiscan**<sup>®</sup>  
systems  
An OSI Systems Company

# RAPISCAN 622XR

## Physical Specifications

Dimensions:	Length: 2,282 mm (89.9 in.) Width: 1,030 mm (40.6 in.) Height: 1,467 mm (57.8 in.)
Tunnel Size:	750 mm (W) x 550 mm (H) (29.5 x 21.7 in.)
Conveyor Speed:	0.20 m/sec (39.4 ft./min)
Conveyor Load:	165 Kg (364 lbs)
Conveyor Height:	788 mm (31.0 in.)
Approx Weight:	Net: 610 Kg (1,345 lbs)
System Power:	115/230 VAC ±10%, 60/50Hz

## Standard X-Ray Generator and Image Performance\*

Steel Penetration:	28 mm guaranteed; 30 mm typical
Wire Resolution:	38 AWG guaranteed; 40 AWG typical
Material Separation:	Low Z, Medium Z, High Z to 0.5 Z accuracy
Generator Cooling:	Sealed oil bath with forced air
Anode Voltage:	Operating at 140kV
Tube Current:	0.7 mA
Orientation:	Vertically Upward

## High Penetration X-Ray Generator Option and Image Performance\*

Steel Penetration:	35 mm guaranteed; 40 mm typical
Wire Resolution:	38 AWG guaranteed; 40 AWG typical
Anode Voltage:	Operating at 160kV
Tube Current:	1.0 mA

## Operating Environment

Storage Temperature:	-20°C to 50°C
Operating Temperature:	0°C to 40°C
Relative Humidity:	5 to 95% non-condensing

## Health & Safety

Rapiscan Systems' cabinet X-ray products comply with all applicable US FDA and equivalent international regulatory agency requirements, contained in the cabinet X-ray radiation safety performance standard [21 CFR 1020.40] and the general performance standard [21 CFR Part 1010]. Rapiscan Systems certifies each cabinet X-ray product has a maximum radiation emission leakage of less 1 µSv/hr (0.1 mR/hr) from all external surfaces of the cabinet X-ray system.

## Options and Accessories

Target™ / Interactive Target™ (Automatic detection of solid explosives)	Computer Based Operator Training (CBT)
NARCSan™ (Automatic detection of narcotics)	Operator Training Program (OTP)
Density Threshold Alert (DTA)	Manual Scan
Threat Image Projection (TIP)	Operator Pedestal
Threat Image Projection Network (TIPNet)	Foot-mat
NETView™ (Remote network image archive review)	Optical Operator Presence Sensor
NEXLink™ (Advanced network X-ray management automation and link system)	SmartCard Login
Multi-System Alarm Resolution Network Display Station (NDS)	Power Conditioner
Automatic Image Archiving	Conveyor Accessories
Enhanced Image Archiving	Remote Workstation
	Adjustable Height Lift and Tilt Stand
	High Penetration X-ray Generator
	Universal Printer Support

\*Stated performance as measured by Rapiscan Imaging Validation Test Kit.

With continual development of our products Rapiscan Systems reserves the right to amend specifications without notice. Product pictures are for general reference. Please note that due to US laws and regulations, not all Rapiscan products are available for sale in all countries without restriction. Please contact your Rapiscan Systems sales representative for more information.

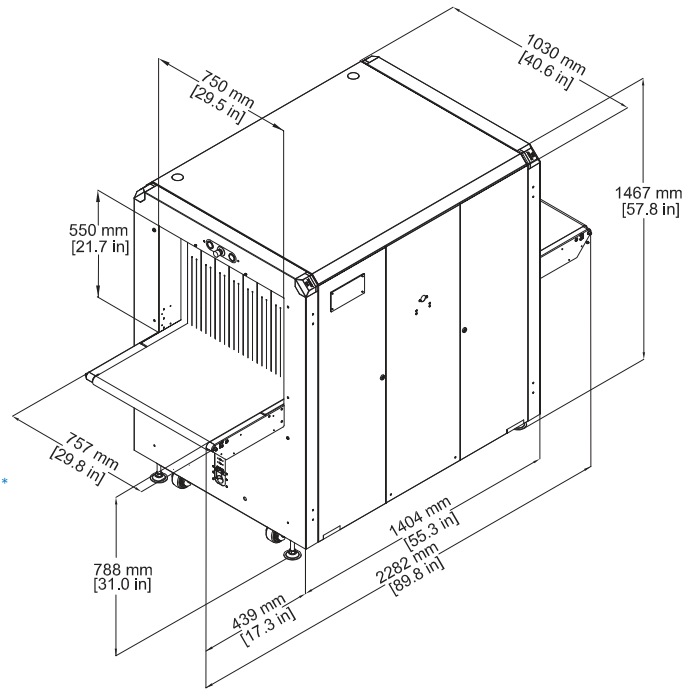

## AMERICAS, CARIBBEAN

2805 Columbia Street  
Torrance, California 90503  
UNITED STATES OF AMERICA  
Tel: +1 310-978-1457  
Fax: +1 310-349-2491

## EUROPE, MIDDLE EAST, AFRICA

X-Ray House  
Bonehurst Road  
Salfords  
Surrey RH1 5GG  
UNITED KINGDOM  
Tel: +44 (0) 870-7774301  
Fax: +44 (0) 870-7774302

## ASIA

240 Macpherson Road  
#07-01 Pines Industrial Building  
Singapore 348574  
SINGAPORE  
Tel: +65-6846-3511  
Fax: +65-6743-9915

## EMAIL

sales@rapiscansystems.com

## WEB

www.rapiscansystems.com

**Rapiscan**  
systems

An OSI Systems Company



Rapiscan Systems is  
ISO 9001:2008 Certified

ONE COMPANY - TOTAL SECURITY

www.rapiscansystems.com